



KINGPIN™

PINTLE CHAIN

Open-Barrel Pintle Chain

(All dimensions listed in inches)

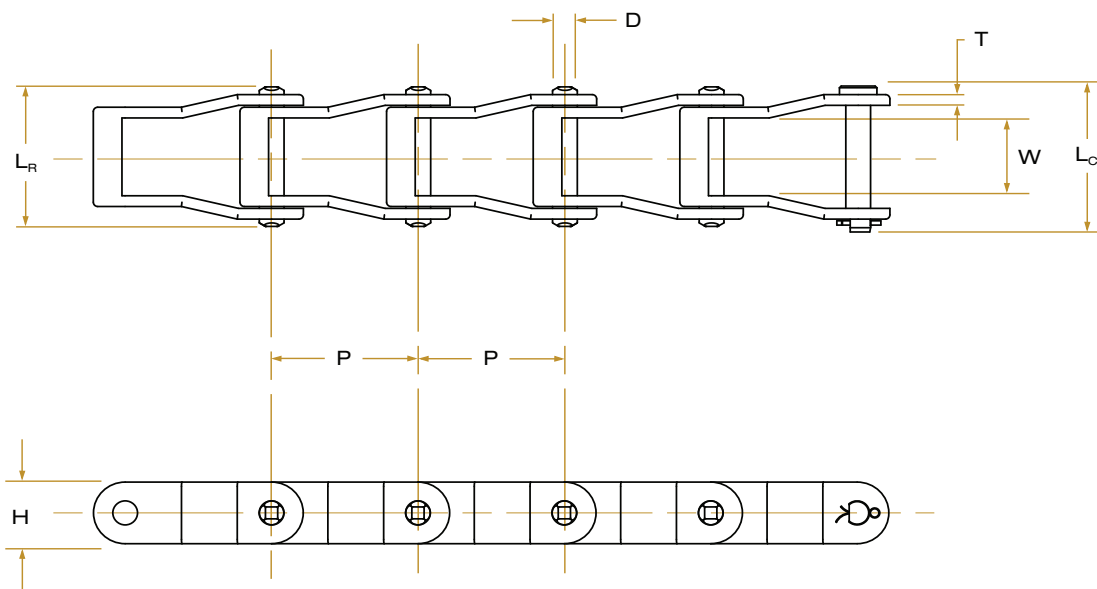

Chain Number	Pitch	Pin Diameter	Plate Thickness	Height	Pin Length		Inside Width	Min. Ultimate Tensile Strength (lbs)	Average Tensile Strength (lbs)	Max Working Load (lbs)	Weight per Foot (lbs/ft)
	P	D	T	H	L _r max	L _c max	W				
662	1.664	0.281	0.125	0.720	1.625	1.680	0.906	8,500	11,400	1,700	10.5
667J	2.250	0.375	0.170	0.937	2.047	2.130	1.063	14,000	20,600	2,800	18.1
667X	2.250	0.437	0.170	0.937	1.953	2.184	1.063	15,000	22,100	3,000	18.6
667KC	2.250	0.437	0.200	1.062	2.125	2.307	1.078	24,000	31,500	5,200	28.0
667XH	2.250	0.469	0.224	1.062	2.313	2.516	1.078	26,000	33,800	5,200	28.0
667H	2.313	0.312	0.125	0.875	1.734	1.889	1.000	9,500	13,100	1,900	11.7
88K	2.609	0.437	0.200	1.062	2.125	2.133	1.078	20,000	27,500	4,000	23.0
88C	2.609	0.500	0.250	1.125	2.641	2.787	1.250	30,000	38,800	6,000	33.2